



THE CV-414 (SC) SERIES

Operating and Service Manual

Series includes all variants of CV-414 (SC)

Issue B
APRIL 2021



TABLE OF CONTENTS

1. Description	3
2. Installation	3
3. Operation	4
4. Special Conditions for Safe Use	4
5. Hazardous Location Usage	4
6. Servicing and Maintenance.....	5
6.1. Replacing the burst disc.....	6
6.1.2. Figure 1 – Sectional View of the CV-414 (SC).....	8
7. Technical Data.....	9
8. Warranty Statement	9

1. Description

The CV414-SC is a self-closing cylinder valve for high pressure gas systems, offering users a quick and simple disconnect feature.

The CV414-SC can be offered with either a 5/8"-18 UNF (Male) or M18 x 1.5 (Male) cylinder connection. Also, as an optional extra, a burst disc may be added to protect the system against over-pressurisation. *(please refer to CV414 data sheet for further information)*

Pressure Equipment Directive (PED) 2014/68/EC Declaration

This equipment is designed and manufactured in accordance with Sound Engineering Practice (SEP) Article 4, Paragraph 3 of the directive 2014/68/EC. As such, CE marking must not be applied. The equipment is marked under section 3.3 of Essential Safety Requirements of the directive.

Note: This product is a non-serviceable product, apart from the replacement of the burst disk *(please refer to section 6.1)*. For any replacements or more information, please contact the Pressure Tech Office.

2. Installation

Before system start-up, it is recommended that all lines should be free from any form of contaminations, as those can affect CV414-SC's performance and functionality. All systems be pressure tested, leak tested and purged with an inert gas such as nitrogen.

Prior to placing into service ensure that the valve is in the fully closed position, ensuring that there is no excess gas leaking from the valve.

Prior to installation visually inspect the CV414-SC for any signs of damage or contamination. If any foreign materials are present and cannot be removed from the CV414-SC, or if the threads on the CV414-SC appear to be damaged, please contact the office immediately to arrange for the valve to be returned for service.

To connect the CV414 to the cylinder:

- i. Screw the CV414 via the Stem into the relevant thread of the cylinder.
- ii. Using a 28mm open ended spanner against the flats of the CV414 body, tighten to 20Nm against the cylinder. Ensuring that the base of the CV414 is flat against the top of the cylinder.

To connect a regulator to the CV414:

- i. Screw the coupling nut to the top of the CV414 (M25 x 1.5 LH thread)
Note: The final half a turn will activate the CV414.
- ii. Tighten the Coupling nut to 2.5Nm, using a 27mm open ended spanner.

3. Operation

The CV414-SC series of valve that houses a normally closed operating mechanism, that is actuated by a separate operating device, which is not an integral part of the cylinder valve.

The operating device (i.e. regulator) opens the valve orifice and closes automatically when or before the operating device is disconnected.

If a cylinder refill is required, the CV414-SC's low torque design means it is easy for users to disconnect* the valve from the regulator to isolate the gas supply, even under high pressure, whilst the valve remains attached to the gas cylinder.

*To disconnect the CV414 from the regulator:

- i. Loosen the coupling nut, by half a turn. This will shut off the CV414 and also vent any excess gas pressure between the upper chamber of the CV414 and the base of the regulator.
- ii. Once all the excess gas pressure is depleted, it is then safe to completely unscrew the coupling and remove the regulator from the CV414.

4. Special Conditions for Safe Use

The CV414 -SC series require manual venting; therefore, the excess pressure shall be reduced by venting downstream of the valve (i.e. via the regulator).

5. Hazardous Location Usage

This equipment has not been manufactured specifically for use in potentially explosive atmospheres and as such an ignition hazard assessment has not been carried out on this product. If the user should wish to use this product in such an environment where there may be a potentially explosive atmosphere then it is the responsibility of the user to conduct an ignition hazard assessment against 99/92/EC.

6. Servicing and Maintenance

Servicing and maintenance work on the CV-414 self-closing valve should only be performed after fully reading and understanding the Operating and Servicing Manual. Due to the compressibility of gases, the operator should not endanger themselves or others by working on this self-closing valve without prior knowledge of the Health and Safety risks relating to handling of technical gases. Any uncertainty should be clarified with Pressure Tech before working on the regulator.

Pressure Tech Ltd recommends the use of Krytox GPL 205 as a lubricant for O-rings during servicing.

Prior to commencing service, please ensure that:

- The equipment has been de-pressurised
- Applications involving toxic, flammable or corrosive media have been fully purged

To ensure the best possible results from servicing, when re-assembling the regulator and any assemblies within it, ensure that all areas of the components and the regulator body are cleaned and free from contaminants which may result in failure of the CV414.

6.1. Replacing the burst disc

Note: figure 1 should be used as a reference for the following set of instructions

The CV414 may be supplied with different types of burst disc, dependent on the thread type and pressure. (*please refer to CV414 data sheet for further information*)

Below are main two types of burst disc supplied, based on their thread type. (*please refer to fig 1 – Location ‘A’ Burst Disc Housing*)

- **BD1** – 3/8” -24 UNF
- **BDO** – M11 x 0.75

IMPORTANT: Before replacing the burst disc, ensure that all the pressure is depleted from the CV414 Valve.

To replace the BD1 burst disc:

- i. Unscrew the failed unit, using a 3/8” hex socket* and then discard it. (as this is not serviceable)

*Note: Socket should have close fit in order to avoid damage to hex section.
- ii. Visually inspect the burst disc housing port for damage or debris. If the port is damaged, do not replace the disc. Consult with Pressure Tech on further actions or possible replacement.
- iii. Screw the new burst disc, into the burst disc housing port and tighten to 11 – 15Nm using a 3/8” hex socket*.

*Note: Socket should have close fit in order to avoid damage to hex section.
- iv. To ensure that the burst disc has been correctly and effectively installed, it may be required to perform the appropriate seat leak test.

This can be carried out by gradually increasing the supply pressure and apply a leak detection fluid (pressure-tech recommends Swagelok Snoop fluid), until the product maximum working pressure is achieved (*Please refer – page 9*).

Note: where leakage is present, please ensure that deplete all the pressure from the CV414 and then carry out an investigation to determine the cause of failure.

To replace the BDO type burst disc:

- i. Unscrew the burst disc nut, using a 6mm Allen/hex key.
- ii. Remove the failed Burst Disc Foil and then discard it. (as this is not serviceable)
- iii. Visually inspect the burst disc housing port for damage or debris. If the port is damaged, do not replace the disc. Consult with Pressure Tech on further actions or possible replacement.
- iv. Insert the new burst disc foil, with the flat surface leading into the burst disc housing.
- v. Screw the burst disc nut, with the raised face into the burst disc housing port and tighten against the burst disc foil to 20 – 25Nm using a 6mm Allen/hex key.
- vi. To ensure that the burst disc has been correctly and effectively installed, it may be required to perform the appropriate seat leak test.

This can be carried out by gradually increasing the supply pressure and apply a leak detection fluid (Pressure Tech recommends Swagelok Snoop fluid), until the product maximum working pressure is achieved (*Please refer – page 9*).

Note: where leakage is present, please ensure that deplete all the pressure from the CV414 and then carry out an investigation to determine the cause of failure.

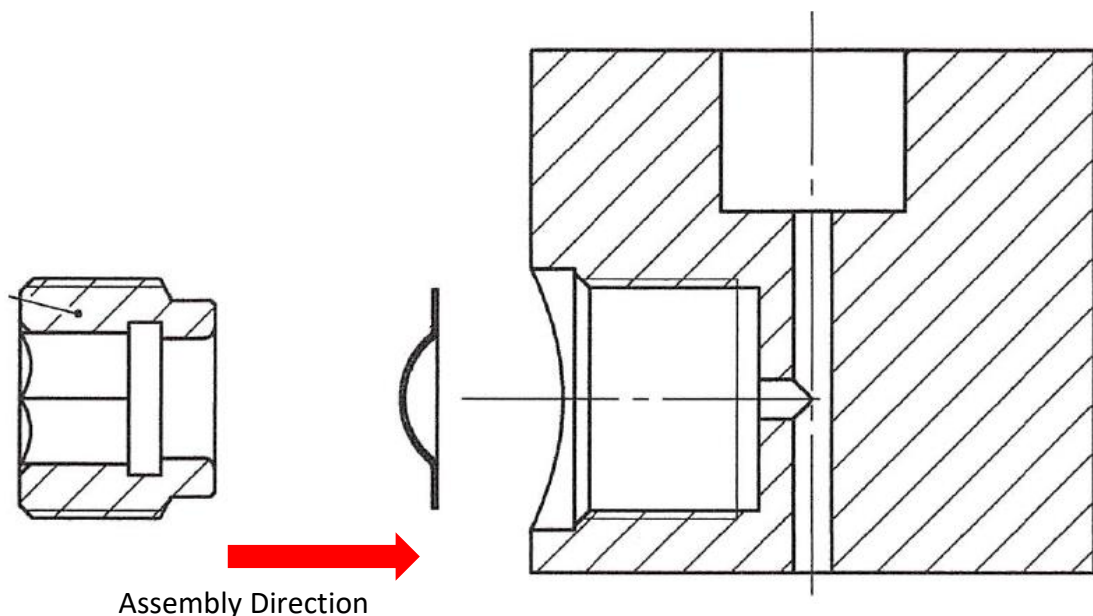

* ALL DIMENSIONS IN MILLIMETERS, UNLESS OTHERWISE STATED.

6.1.2. Figure 1 – Sectional View of the CV-414 (SC)

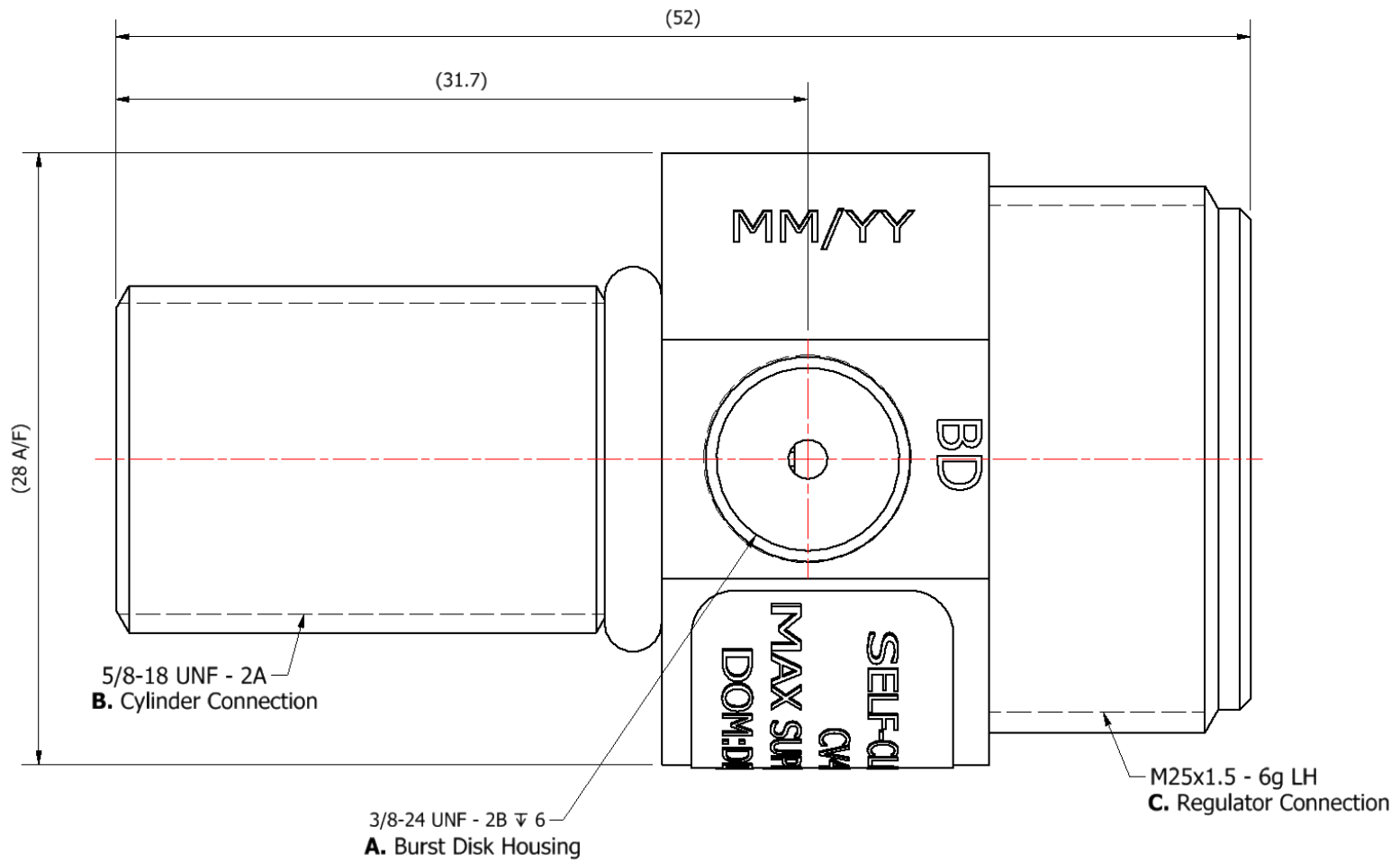

© Copyright of Pressure Tech Ltd

7. Technical Data

Fluid Media:	All gases and liquids compatible with materials of construction
Max Inlet Pressure:	414 bar (6,000 psi) with PEEK Seat 350 bar (5,075 psi) with PCTFE Seat (TPED Approved)
Operating Temperature:	-40°C to +65°C
Materials:	Body and Trim: 316 SS Seat: PCTFE or PEEK®
Flow Capacity (Cv):	0.06
Leakage:	Gas: Bubble tight

8. Warranty Statement

Pressure Tech Ltd guarantee all products correspond with their specification at the time of delivery and, with exception to wear and tear, wilful damage, negligence, and abnormal working conditions, will be free from defects for a period of 12 months from date of delivery.